



POWER CURBER 5700-D

#1 In The World

The One-Machine Solution

Curb & Gutter | Highway Safety Barrier | Sidewalks | Special Applications

About Power Curbers

Our Commitment Shows

Power Curbers was established in 1953 and has been the leader in slipform machines for more than 65 years. Based in Salisbury, NC, USA, Power Curbers is a global provider with machines located in over 100 countries.



Power Curbers Salisbury, NC, USA, manufacturing facility.

The Power Curbers Way

Power Curbers Companies is driven to be the premier slipform machine manufacturer in the world known for our outstanding customer support, quality products, and committed company Associates. Everything we do revolves around four core principles.

People – Our Associates are the key to our success. Beginning with a selective hiring process and thorough training program, we put our people in a position to make a difference for the company and its customers. We create an atmosphere of a family environment, with safe working conditions and career advancement opportunities for all.

Customer Experience - Without our customers we do not exist. We strive to spoil them with outstanding product and parts support, technical expertise, and professional training. Exhibiting integrity in everything we do and demonstrating an unmatched desire to please customers drives every interaction. Since 1953, we demonstrate daily that “Our Commitment Shows.”

Products - We seek to provide the industry with innovative, high quality, simple-to-operate machinery.

Outstanding Processes - In all areas of the company, we are committed to Lean practices. We seek to continuously improve in all business processes, knowing that we never arrive.

The following pages contain information on the latest generation of our number one selling slipform machine in the world, the Power Curber 5700-D. We hope you will find it beneficial. Thank you for your interest in Power Curbers and Power Pavers. We are excited to prove that "Our Commitment Shows."



Welcome to Power Curbers.



Training Center at Power Curbers manufacturing facility.

New With The 5700-D

The latest generation of the number one selling slipform machine in the world

▲ SlipSmart Control System

The upgraded control system brings a number of improvements:

- Cross-slope controls are smoother, more responsive, and intuitive
- Auto-calibration for the radius steer sensor
- Simplified integration with **Topcon, Leica, and Trimble 3-D control systems**
- Fine scaling for speed controls
- Standardized display
- Icons for languages other than English

▲ Control Panel Upgrades

We've kept much of the control panel the same so the 5700-D will feel familiar while including these improvements:

- "All up" jog switch. With a single switch that raises or lowers all crawler posts simultaneously
- Master vibrator scale knob. In addition to individual vibrator control knobs, the new master control increases or decreases hydraulic flow to all vibrators at once allowing the operator to keep individual vibrators higher or lower relative to each other
- Multiple individual engine gauges are replaced by a single display
- Weather proof switches
- Trimmer "on" light
- Descriptive etched wire labels matching machine schematics
- Cold air dam between engine and console to better regulate control panel temperature and increase operator comfort
- Lightweight aluminum console lid replaces heavy steel lid
- Cup holder

▲ Additional Improvements

- High-pressure water system uses a new pump that can be left "on" without system wear. On-demand high-pressure water will be activated by the wand's handle
- **New canopy with an overhead lamp** available in addition to existing bimini and umbrella choices
- New door latch style and new doors added to each end of the toolbox. Engine door double latches combined into a single, lower latch
- Auger Conveyor pivot is easier to rotate and the hopper features shovel holders on both sides
- Improved rigidity in mold offset
- Improved **low-pressure water system** with new pump
- **Barrier Mold Lift** range increased to 48" (1220mm)

Optional accessories are shown in red.



Pouring curb & gutter with 3-D (stringless) control.

Design Strategy

Simplicity & Productivity

At Power Curbers we believe in keeping things simple. Our engineering and design are based around providing customers with an easy to operate, reliable, and productive machine. This design strategy is evident throughout the 5700-D.

▲ Compact Design

The 5700-D's compact design allows operators to get in and out of tight spots like parking lot corners, islands and cul-de-sacs. The machine transports at legal width (8'6"/2.59m) and does not require a low-boy.

▲ Visibility

The operator has an excellent view of concrete as it exits the mold, allowing adjustments immediately to minimize handwork behind the machine. The operator also has good visibility of all activity around the machine.

▲ Front Track Steering

In keeping things simple, the 5700-D turns tight radii by steering the front track only, eliminating coordinating all three tracks together. However, **all-crawler steering** is available as an option. (See page 10.)

▲ Stringless Capable

All-crawler steering equipped machines are ready to work with **Topcon**, **Leica**, and **Trimble 3-D systems**.



Machine maneuvers in tight areas, minimizing tie-ins.



Loading and unloading is quick, and a low-boy isn't required.



Operator has great visibility of entire process.



The 5700-D is fully stringless capable

Maximum Productivity & Jobsite Versatility

What makes the 5700-D the most productive slipform machine in the world?

▲ Auger Conveyor

After years of building machines with conveyor belts and dealing with their inherent problems like ripping in the middle of a pour and the concrete splatter they cause, Power Curbers introduced the auger conveyor in 1994.

The direct drive, high torque auger:

- Moves volume concrete faster
- Keeps the machine cleaner
- Continues the mixing process of the concrete
- Holds a cubic yard (3/4m³) of concrete which is beneficial in radius and cul-de-sac work
- Conveys concrete regardless of the incline angle of the conveyor

The unique ability of the charge hopper to be positioned in front of the machine, allows a concrete truck to run directly in front of the machine enabling pouring in a single lane of traffic.

▲ Hydraulic Adjustable Offset

The mold mount hydraulically raises, lowers, and side-shifts the mold quickly and easily. With 24" (610mm) of horizontal movement and 16" (406mm) vertical, the mold can be lowered into a trench for rehab curb or for pouring adjacent to existing pavement.

At catch basins, the machine never leaves the stringline and the mold can be positioned within inches of the obstacle, reducing labor intensive tie-in work.

▲ Trimmer

The stout 42" (1.07m) wide carbide-tooth trimmer handles the toughest of subgrade, minimizing dependence on the grading contractor. Ideally the trimmer cuts 1-2" (25-50mm) of subgrade, but is capable of trimming up to 6" (150mm) in extreme situations.

The trimmer also hydraulically side shifts 80" (2.03m) enabling the ability to trim for a 5' (1.5m) radius or to move the trimmer under the machine and out of the way when not in use. With 16" (406mm) of hydraulic vertical movement, the trimmer can lift over catch basins and other obstacles.

▲ Pour on the Left and Right Side

The standard setup of the 5700-D is for left side pouring. For highway projects where pouring with traffic is required, the **dual side pouring option** is available.



Auger Conveyor; lid opens for cleaning.



Hydraulic Adjustable Offset.



Trimmer lifting over catch basin to pour the curb as closely as possible.



Heavy duty trimmer with extension.

More Than A Machine — It's A

A full understanding of the entire process is the key to success

▲ Jobsite & Machine Set-up

- Grading and site preparation ahead of the curb machine is important to productivity and quality.
- Stringline is set by referencing the surveyor's stakes.
- Accurate and tight stringline placement is very important to the quality of work.
- The 5700-D, equipped with sensors for steering and elevation control, follows the stringline automatically around the jobsite.
- Machine follows stringline around a 2' (610mm) radius.

▲ Ready-Mix Supply

- Consistent concrete mix design and slump is important to both productivity and quality.
- Steady supply of concrete is often the biggest determining factor in daily production.
- Recommended mix design will vary by application. Contact us for a recommendation.
- Concrete is the biggest variable. A good relationship with the concrete supplier is very important.

▲ Auger Conveyor

- Large capacity charge hopper, low to the ground, allows for easy discharge from ready-mix truck.
- Hydraulically adjustable tilt and slide, and manual pivoting – position it exactly where it needs to be for a day's pour.
- Long-lasting, segmented cast flighting lasts much longer than a belt.
- Delivers concrete up to 2 yards³ (1.5m³) per minute.
- The enclosed housing contains the concrete, keeping the machine clean and continues the mixing process all the way to the mold hopper.
- Lid opens for cleaning.
- Discharge chute is adjustable, further allowing for positioning flexibility of the auger

▲ Trimmer

- Cuts grade allowing pouring without wasting concrete or running the mold into high spots.
- Allows the mold and the soil to intersect, creating a perfect seal.
- Extensions available for trimming up to 78" (1.98m) wide.
- Choice of carbide teeth – bullet or chisel point – depending upon soil type and conditions.
- Vertically and horizontally adjustable, independent of machine positioning. Adds flexibility in radius work, rehab, and sidewalk.
- Moves out of the way when pouring barrier or when steel is fed into the mold.

▲ Slipform Process

- Large capacity mold hopper.
- Constant head pressure, or the amount of concrete in the hopper, produces consistent results.
- Vibrators mounted into mold hopper consolidate concrete and, with gravity and machine movement, force it through the mold.
- Vibrator positioning is critical for filling the mold and producing a smooth finish. Mounting is easily adjustable in order to accommodate different mold shapes and sizes.

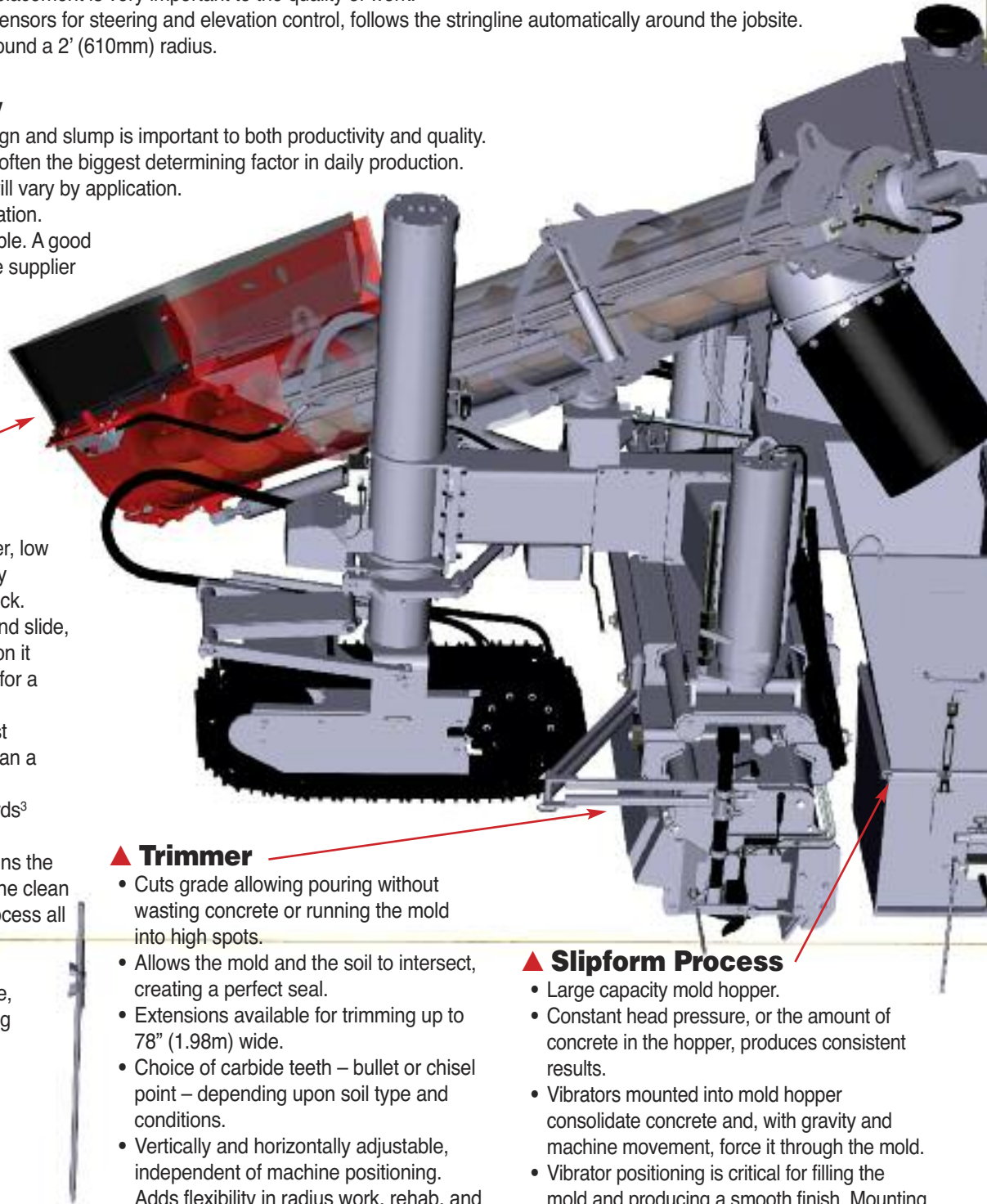

Mobile Manufacturing Plant

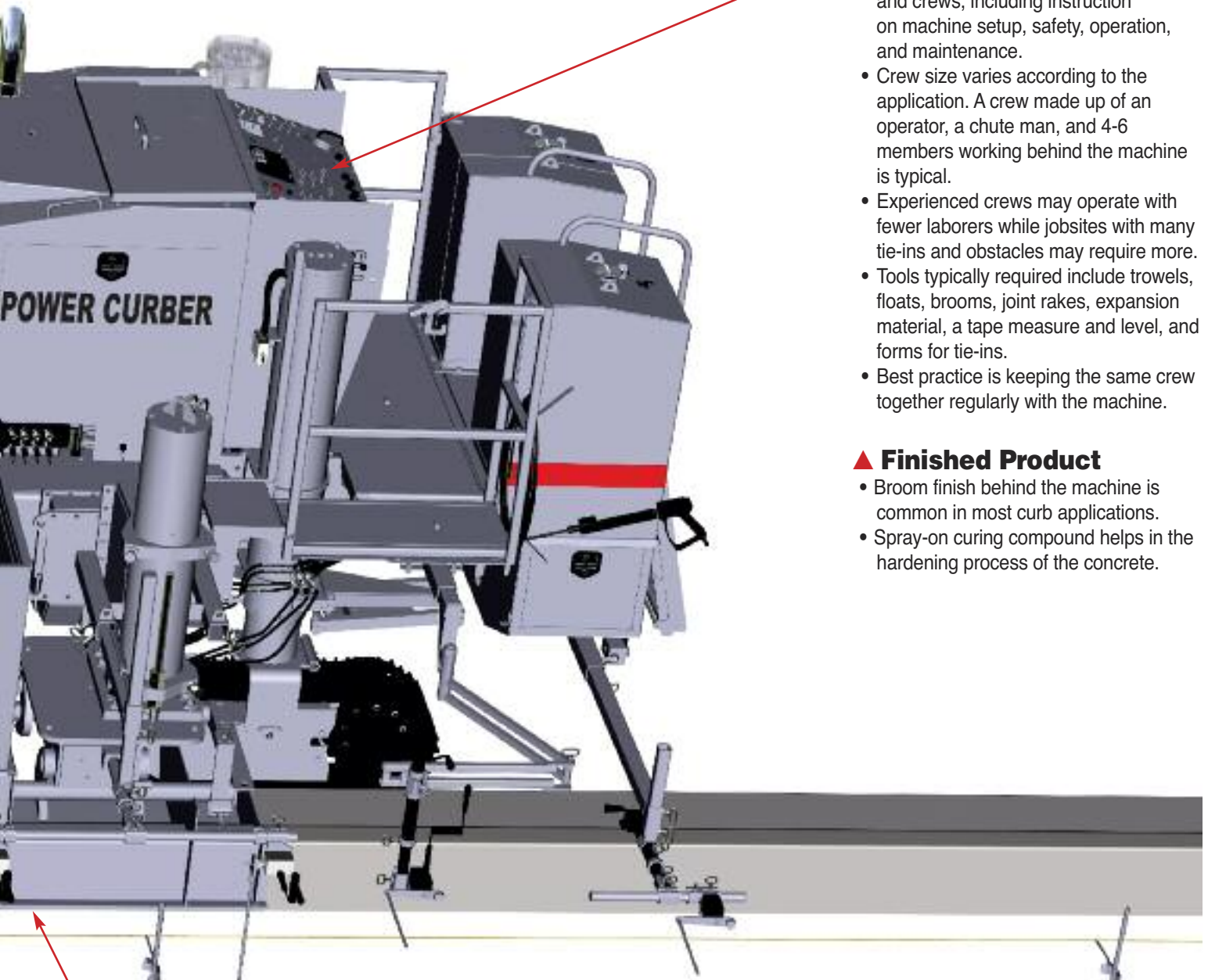

▲ Operator & Crew

- We offer jobsite training for operators and crews, including instruction on machine setup, safety, operation, and maintenance.
- Crew size varies according to the application. A crew made up of an operator, a chute man, and 4-6 members working behind the machine is typical.
- Experienced crews may operate with fewer laborers while jobsites with many tie-ins and obstacles may require more.
- Tools typically required include trowels, floats, brooms, joint rakes, expansion material, a tape measure and level, and forms for tie-ins.
- Best practice is keeping the same crew together regularly with the machine.

▲ Finished Product

- Broom finish behind the machine is common in most curb applications.
- Spray-on curing compound helps in the hardening process of the concrete.

▲ Mold

- All molds are custom built according to application specifications.
- Concrete flows from the mold hopper into the throat of the mold and exits past the screed/finishing plate.
- Screed section is adjustable allowing air to escape the concrete before final finishing.
- Rear of mold is aligned with the pivot point of the machine allowing for accurate concrete placement in tight radius work.
- Operator has great view of concrete as it exits the mold, adjustments can be made immediately

Addressing these points contributes to a smooth completed product with very little hand finishing required.

Curb & Gutter and Rehab

5700-D has the features to make tough work easier



Tapered curb & gutter, poured over dowels adjacent to the pavement.



Curb & Gutter in a rehab application

Though used in a variety of applications, the 5700-D is most often used for pouring curb or curb & gutter. From sprawling subdivisions to highway DOT work, to cramped parking lot islands, the 5700-D has labor-saving features to increase productivity.

▲ Quick Connect Mold Mount

Our most popular optional feature, the patented **Quick Connect mold mount**, allows

mold changes in as little as five minutes. The hydraulically activated hooks release one mold and grab the next one with little manual work. For contractors changing molds often on jobsites or going from one application to another in the same day, our Quick Connect makes the job quick and easy. In addition to picking up the mold, it automatically aligns the mold and locks it securely in place.

▲ Hydraulic Mold Offset Lock

After using the hydraulic adjustable offset to position the mold, the optional **hydraulic mold offset lock** enables the operator, at the flip of a switch, to lock the offset rigidly to the machine. Firmly locking the mold to the machine eliminates play in the mold which can affect the finished product. The standard is a manual mechanical lock.

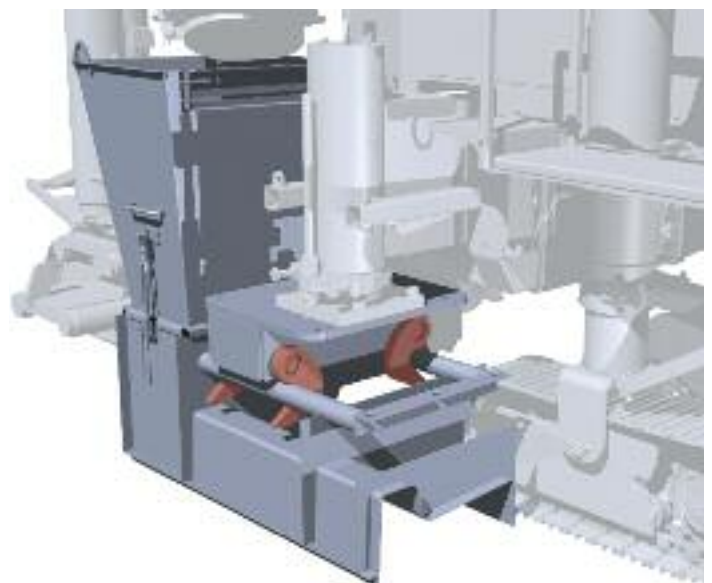

Quick Connect makes mold changes easy.



The machine's tight radius capability eliminates hours of hand forming and produces a higher quality product.

▲ Radius Work

Pour islands as tight as 2' (610mm). Our tight radius abilities make the 5700-D ideal for parking lot islands. Eliminating days of hand labor in large retail parking lots, the 5700-D can handle the narrowest of parking lot islands.

For work in areas with less extreme radii the optional **hydraulic front grade sensor arm** allows the front sensor to stay on line without manual adjustment.

▲ Mold Options

Our curb & gutter **molds** can be built with a variety of options to give you added flexibility on the jobsite. Options include **block-outs** for varying the curb width, **extensions** for varying the curb height, and **removable side plates** for pouring adjacent to existing pavement.

For pouring through driveway cuts, we offer two options of labor and concrete saving **driveway knives**. One uses a rotating plate, while the other uses a side-entry tapered plate that reduces hand finishing on top of the curb. Please contact our mold department or visit the molds page of our website (www.powercurbers.com) to learn about the many options we offer in mold design.

Optional accessories are shown in red.



Driveway knives reduce wasted material and labor. Some hand finishing is required.



The machine handles muddy and rough conditions.

Barrier/Parapet Applications

Enhance the 5700-D with equipment specific to your work

Though Power Curbers has poured barrier wall for decades, the evolution of the 5700-D has allowed us to pour larger barrier than ever before. In addition to standard Jersey barrier, the 5700-D pours variable barrier and other vertical structures for tunnels and high speed rail. The low center of gravity and size-to-weight ratio makes the 5700-D ideal for barrier and parapet.

▲ Barrier Mold Lift

At the end of a day's pour, the hydraulic barrier mold lift allows you to raise the mold up and off the steel cage. With 48" (1220mm) of stroke in the mold lift and 36" (914mm) of post extension the 5700-D can clear tall steel cages, allowing you to quickly move the machine out of traffic for cleanup and until the next day's pour.



5700-D-MAX equipped with barrier mold lift.

▲ All-Crawler Steering

In large applications like variable barrier or wall adjacent to an existing structure, our all-crawler steering option is an added benefit. In these large applications, coordinating the steering of all the crawlers can enhance the machine's performance.



5700-D-MAX pouring bridge parapet over reinforcement. Includes optional canopy.



Variable Barrier, 57" (1.45m) tall.

▲ Variable Barrier Molds

Contractors pouring barrier on highways with super-elevations love the ability of the 5700-D to tackle these walls. The 5700-D pours with **variable barrier molds** typically weighing between 8,000-10,000 lbs. (3630-4535kg) and with up to 24" (610mm) of variability.

▲ Parapet Sensor Mount

Like barrier, the 5700-D pours bridge parapet in a variety of configurations. To help set up for parapet pours, Power Curbers offers a **parapet sensor mounting kit** and weighted, **free-standing stringline stations**.

Other optional accessories frequently used when pouring barrier include **polyurethane track pads** and **weight pods**.

Optional accessories are shown in red.



Variable barrier, up to 58" (1.47m) tall.



Pouring barrier over rebar cage.



Parapet sensor mounting.



Close up of Bridge Parapet



Variable barrier, up to 68" (1.72m) tall.

Sidewalk, No-Mow Strips & Wide Paving

5700-D offers flexibility and options for flat slipform paving



Monolithic curb, gutter, and sidewalk.



Pouring a 6' sidewalk.

▲ Sidewalk

The 5700-D pours sidewalk or monolithic sidewalk and curb up to 7' wide (2.1m) in the offset position. Equipping the machine with **trimmer extensions**, allows the cut to match the sidewalk.

The 5700-D's adjustable offset allows pouring behind existing curb and over planter strips. **Sidewalk mold** options include **detachable side plates** for pouring adjacent to curb and for secondary sidewalk widths.



The 5700-D is an all-in-one solution for installing no-mow strips for cable barriers.



Apron addition over steel, sensing off existing pavement.

▲ Cable Barrier Installations

In some highway applications as an alternative to concrete barrier, cable barrier is used. In these applications the 5700-D contributes in two ways. Using a **custom mold** in the traditional setup, the machine easily pours a "no-mow" concrete strip which reduces vegetation maintenance under barrier cable.

Before paving the no-mow strip, our **post hole digger** attachment allows quick and accurate bore holes for anchor posts. Because of the automatic steering and leveling of a slipform machine, the holes are bored more accurately than with traditional auger equipment. Then, pour over the holes and insert the post sleeves into the wet concrete.

▲ Center Pour Paving

The 5700-D can be converted into a center-pour paver for wide golf cart and bicycle path paving. Using inserts, the right rear crawler post is moved to allow a paving mold to be installed for widths up to 10' (3m).

Sectionalized with side plate assemblies and inserts at 4' (1.5m), 2' (1m), and 1' (.5m) widths, the **center pour kit** gives the flexibility to pour between 4' (1.5m) and 10' (3m) wide in 1' (.5m) increments. The hydraulically adjustable side plates allow the paving depth to vary up to 12" (305mm) thick.

Conversion from the standard offset paving setup requires dropping the auger conveyor and trimmer. Concrete is dumped directly into a hopper at the front of the mold and the spread auger on the paving package spreads the concrete across the hopper.

Optional accessories are shown in red.



Center pour paving 10' (3m) wide. Concrete is dumped directly into a hopper at the front of the paving mold.



Using trimmer extensions.



Sidewalk adjacent to back-of-curb.
Sensing off-curb.



Paving 10' (3m) wide. Center pour paver is sectional for varying paving widths.

Special Applications

The 5700-D is as versatile as it needs to be



Ditch Liner in Turkey, 12.5' (3.8m) wide and 2' (.6m) deep, adjacent to pavement on both sides. (shown with custom belt conveyor)



V-Ditch in Equatorial Guinea, 7' (2.2m) wide and 18" (.45m) deep, poured adjacent to pavement.

▲ Ditch Liners

Frequently in mountainous areas, concrete lined ditches are required for water control. **V-ditch molds** easily mount to the 5700-D similar to sidewalk molds. Because the trimmer cannot be used in V-ditch applications, preparation of the ditch profile in front of the machine is critical for good results and to avoid wasted concrete. The 5700-D pours ditch liners up to 7' (2.2m) wide and 2'

(610mm) deep in the offset position.

▲ Slotted Drain

One unique application for the 5700-D is for slotted drain pours. In this application, an inflated polymer-based tube is fed into the front of a **custom mold** during the pour. The mold is built with a slot from the gutter pan to the cavity created by the tube. After the concrete has cured, the tube is

deflated and pulled from the curb leaving a hidden drainage channel.

▲ Canals

The size and versatility of the 5700-D makes large multi-pass canal projects possible, with custom engineering from the Power Curbers team. Massive molds and long conveyors can be specifically designed to meet the requirements of the most complex projects.



Slotted drain in Uzbekistan showing inflated tube.



Canal in Australia, base 12' 5.5" (3.8m) wide and sides 6'10" (2.1m) high. (Shown with custom belt conveyor)



Stadium Risers in Peru.

▲ Stadium Risers

The 5700 series machines have poured concrete risers beginning with stadiums used in the 1996 Atlanta Olympics. Since that time Power Curber machines have poured risers for baseball, football and soccer stadiums worldwide. Typically, **custom molds** for this application encompass two risers in one pass. Beginning at the bottom of the stadium, risers are poured and the machine works its way up, running on the risers poured the previous day.

▲ Agricultural Applications

From the foundations of large poultry houses to livestock feeding troughs, to beds and flush lanes in cattle barns, the 5700-D adapts to the job with a variety of **custom molds**.



Custom trencher trimmer and poultry house foundation.



Platform & wall structure poured along a tunnel wall in Turkey – mold is adjustable in height and width to accommodate varying tunnel diameter.

▲ Tunnel Applications

Tunnel jobs include several perfect slipform opportunities for the 5700-D. Inverts with either a curved or flat profile and rail beds can be poured on the tunnel floor. Walls, walkways, and specialized profiles for

housing electrical conduit or other utilities can be poured along the walls. **Custom molds** can be built to adjust in height and width to handle varying tunnel diameter. *Optional accessories are shown in red.*



High-speed rail application in Saudi Arabia using custom rail attachments to pour a utilities trough.

5700-D-MAX

Add the **MAX Package** to Take Command of Large Jobs



Variable barrier pour from 58" to 70" (1.47 - 1.78m) tall.

Consider adding the **MAX Package** to upgrade the capabilities of the machine. Since 1985, Power Curbers has constantly developed and expanded the 5700 series. From its roots as strictly a curb and gutter machine, the 5700 has evolved into the 5700-D, a "one machine does it all" slipform paver.

▲ Features

The **MAX Package** adds yet more capability. It outfits the machine with larger crawlers, all crawler steering, and a secondary mounting location for the rear post. Additional features include low speed crawler torque hubs and three extra vibrator circuits (9 total). These features allow pouring large barrier up to 8' (2.5m) high, paving up to 12' (3.65m) wide, variable barrier with up to 24" (610mm) variability, and other large profile applications.



MAX package pouring large variable barrier wall.

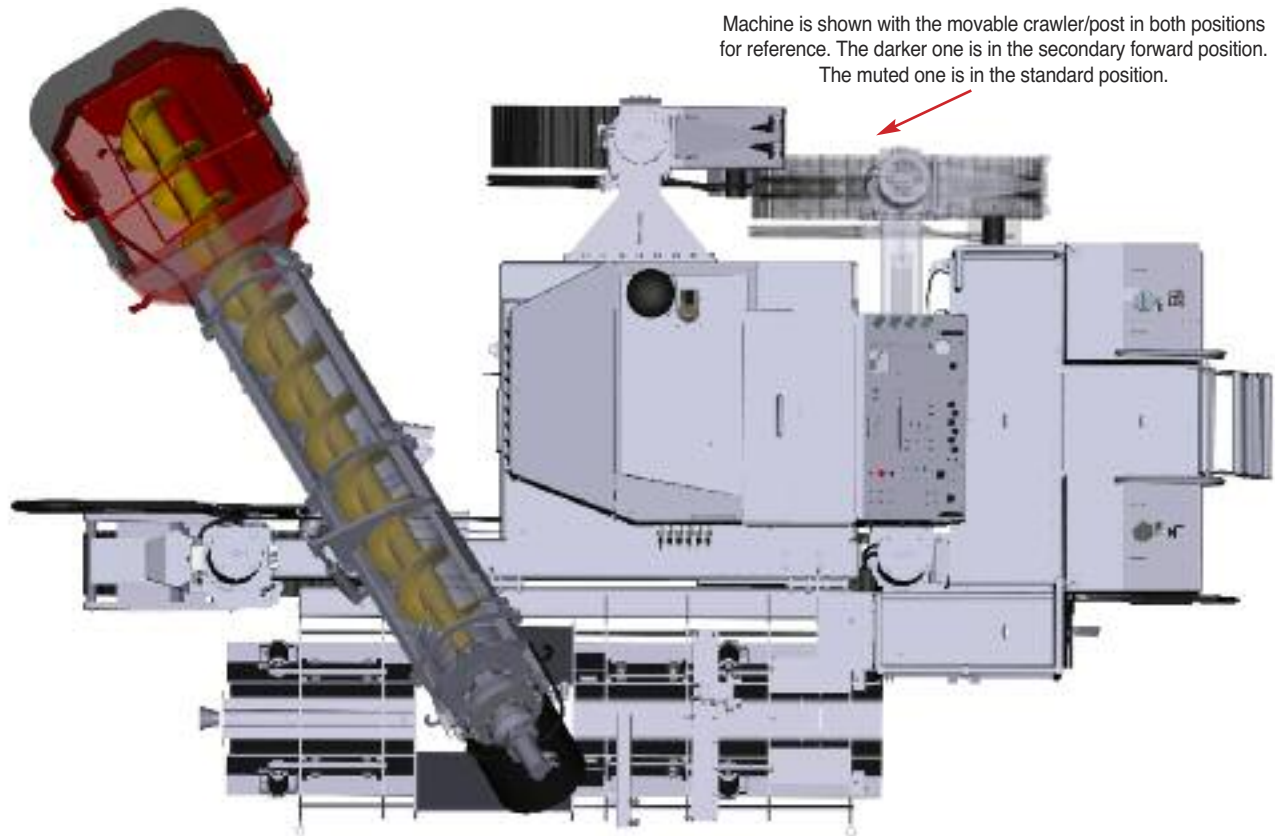

Machine is shown with the movable crawler/post in both positions for reference. The darker one is in the secondary forward position. The muted one is in the standard position.

5700-D-MAX shown with a large variable barrier mold. Machine is also shown in the standard left side pouring configuration.

Crawlers on the 5700-D-MAX are 1' (305mm) longer, heavier, and have an additional roller. This keeps the machine stable even with very large molds and the low-speed crawler torque hubs keep the machine pouring at a steady crawl.

All Crawler Steering, a long-time option on the 5700-D, improves steering accuracy when paving, pouring large walls, and in other demanding applications.

The **MAX Package** includes a secondary mounting location to allow contractors to bring the rear post forward. This changes the machine's geometry and redistributes the weight, improving the machine's performance when using large barrier molds and when paving in the center-pour



Close-up of MAX Package crawlers with polyurethane pads.

position. **Dual side pouring** and our other optional accessories are available to go along with the **MAX Package**.

▲ Still Compact Enough For Curb & Gutter

The rear post can move back to its standard position for curb & gutter work. The machine then turns a 2' (610mm) radius as always and maintains its 8'6" (2.6m) transport width in the standard configuration with C&G mold.

Optional accessories are shown in red.



The rear post on the 5700-D-MAX can be returned to its standard position for pouring curb and gutter.

5700-D

Specifications & Dimensions

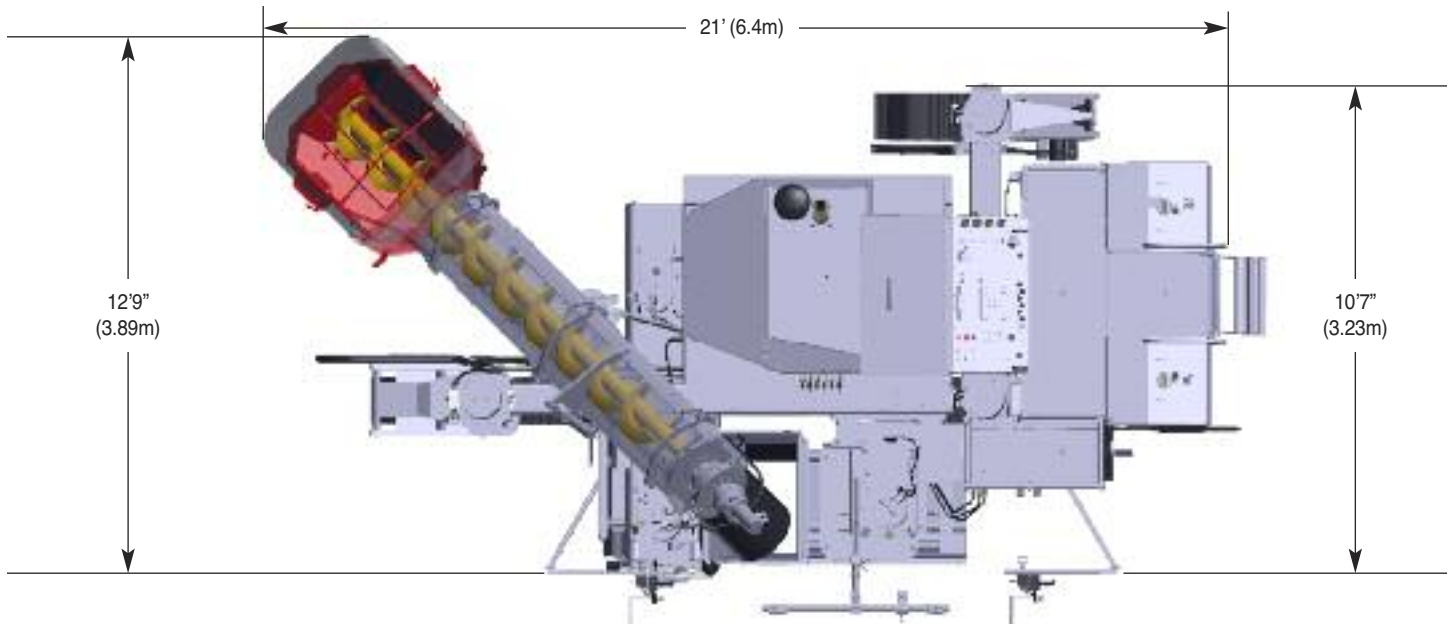

Dimensions are shown with a 24" (610mm) wide Curb & Gutter Mold.

▲ Slipform Paving

Curb/Sidewalk Width: Maximum 7' (2m) in the offset position or 10' (3m) in the center pour position.

Maximum 8' (2.5m) wide offset or 12' (3.65m) center pour with MAX Package.

Barrier/Parapet Height: Maximum 5' (1.5m) Maximum 8' (2.5m) tall with MAX Package.

Mold: One, up to 32" (813mm) wide, with quick release, interchangeable hopper is standard.

▲ Engine

Type: Cummins QSB4.5-130C diesel 4-cylinder/4-stroke, turbo charged, Tier 4f emissions compliant. Optional Tier III emissions compliant engine available where regulations allow.

Power: 130 HP (97kW) @ 2400 RPM

▲ Service Capacities

Fuel Tank: 66 gallons (250 liters)

Hydraulic Tank: 50 gallons (189 liters)

▲ Controls

Power Cubers SlipSmart Control System:

Provides electronic over hydraulic control for grade, forward and reverse steering, and slope.

Features: Adjustment for sensitivity and deadband offering the operator accuracy and feel, without complexity; self diagnostics; and automatic shut-off for sensors that leave the stringline. Networked Digital Control with autoslope, cruise control, 3-D readiness, advanced set-up flexibility, and a large graphic display.

Convenience & Safety: Synchronized

ON/OFF for vibrators & crawlers. Five Emergency-Stop switches and a Horn for operator and chute man.

Light Kit: Four post-mounted spot lights and engine enclosure light

▲ Trimmer

Cutting Width: 42" (1070mm); up to 78" (1980mm) with optional extensions. Carbide teeth.

Cutting Head Diameter: 21" (530mm)

Maximum Trim Depth: 6" (150mm)

Lateral Shift: 80" (2030mm) hydraulically

Vertical Shift: 25" (635mm); 16" (406mm) hydraulically, 9" (228mm) mechanically

Options: Trimmer Extensions in 6" (152mm), 12" (305mm), and 24" (610mm) widths. (Page 12 & 13)

▲ Auger Conveyor

Drive: Direct drive with high torque motor; variable speed and reversible.

Volume: 1 yd³ (3/4 m³) capacity and 0-2 yd³/min (0-1.5m³/min) rate of movement.

Positioning: Pivots, hydraulically tilts and slides 24" (610mm). Discharge chute swivels providing additional flexibility in set-up.

Size: 12' (3.7m) long and 14" (356mm) diameter.

Features: Heavy duty cast flighting with lid for full enclosure.

▲ Vibration

Vibrator Circuits: Six hydraulic circuits with variable speed and independent control.

Vibrators: Two, with adjustable mounts.

Options: Extra vibrator(s) with hanger and extra vibrator circuits (three).

▲ Hydraulic Adjustable Offset

Lateral Shift: 24" (610mm) hydraulically with positive mechanical locking.

Vertical Shift: 25" (635mm); 16" (406mm) hydraulically, 9" (228mm) mechanically.

Option: Hydraulic Mold Offset Lock (Page 8)

▲ Water System

Washer: 2,000 psi (138 bar or 13.8Mpa) high pressure system with trigger control and adjustable spray nozzle.

Tank: Stainless steel with 132 gallons (500 liters) capacity.

Options: Low Pressure system, Mold Misting kit, Charge Hopper Water kit, and Auxiliary Water Tank, 92 gallons (348 liters).

▲ Crawlers & Elevation Posts

Type: Three hydraulically powered crawler tracks with planetary gear reduction.

Tracks: 12" (305mm) wide steel pads

Speed: Travel at 0 - 110'/min (33.5m/min)

0-70'/min (21m/min) with MAX Package

Pouring at 0 - 50'/min (15m/min)

0-35'/min (10.5m/min) with MAX Package

Minimum Turning Radius: Left at 2' (610mm) Right at 20' (6.1m)

Post Extension: 36" (914mm) hydraulic cylinders
Straddle Leg: 22" (559mm) of hydraulic side shift adjustment.

Options: Polyurethane Track pads (page 11) and All Crawler Steering. (Page 10)

▲ Optional Equipment

Quick Connect Mold Mount: Hydraulically operated (Page 8)

Hydraulic Front Grade Sensor Arm: Operator controlled (Page 9)

Dual Side Pouring: Allows pouring from either the left or right side (Page 5)

Barrier Mold Lift: Hydraulically operated, with 48" (1220mm) lift, independent of the machine's post extension. (Page 10)

Weight Pod: 1,980 lbs. (900kg) (Page 11)

Post Hole Digger: 12" (305mm) auger diameter. Maximum hole depth is 34" (864mm) (Page 12). Requires optional Quick Connect Mold Mount.

Center Pour Paving Kit: Available in many widths and configurations (Page 13)

Stringline Accessories: Stakes, rods, clamps, string, radius materials, winches, etc., available individually or in kits.

▲ Net Weight

Machine: 24,700 lbs. (11,200kg)

Weight is approximate and will vary depending on optional accessories and size of mold.

Full Water Tank: Add 1,100 lbs. (500kg)

Full Fuel Tank: Add 480 lbs. (215kg)

Quick Connect: Add 750 lbs. (340kg)

Dual Side Pouring: Add 600 lbs. (270kg)

MAX Package: Add 2,500 lbs. (1,135kg)

Tier III Engine: Subtract 300 lbs. (136kg)

▲ Transport Dimensions

Length: 20' (6.1m).

Add 8" (203mm) for MAX Package

Add 16" (4.9m) for 28' Belt Conveyor

Width: 8' 6" (2.6m)

Height: 8' 1" (2.5m) without exhaust stack

Add 5" (127mm) for MAX Package

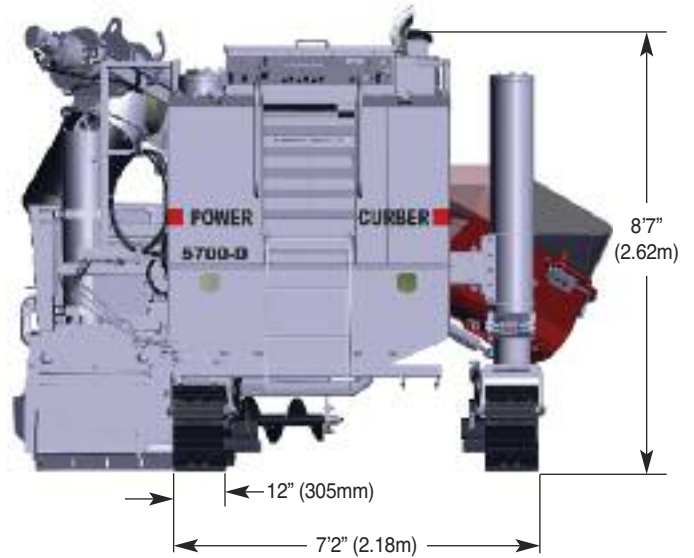

Machine with a 24" (610mm) wide Curb & Gutter Mold.

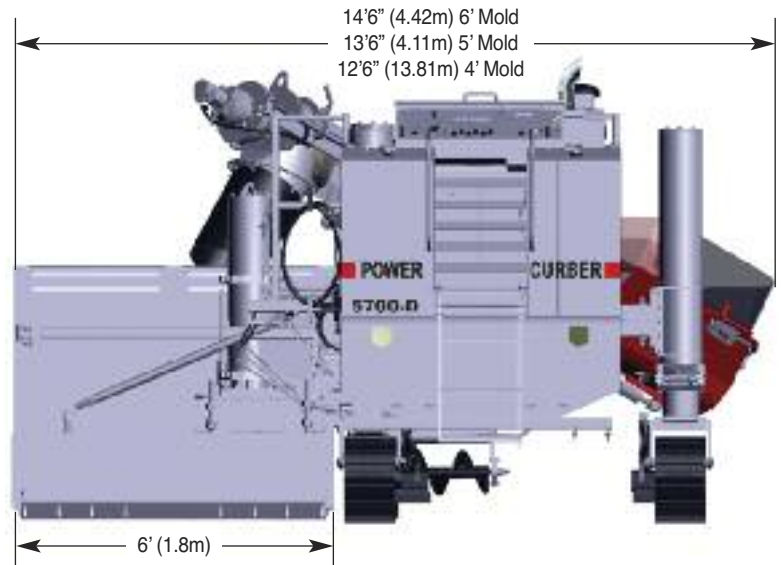

Machine with a 6' (1.8m) wide Sidewalk Mold.

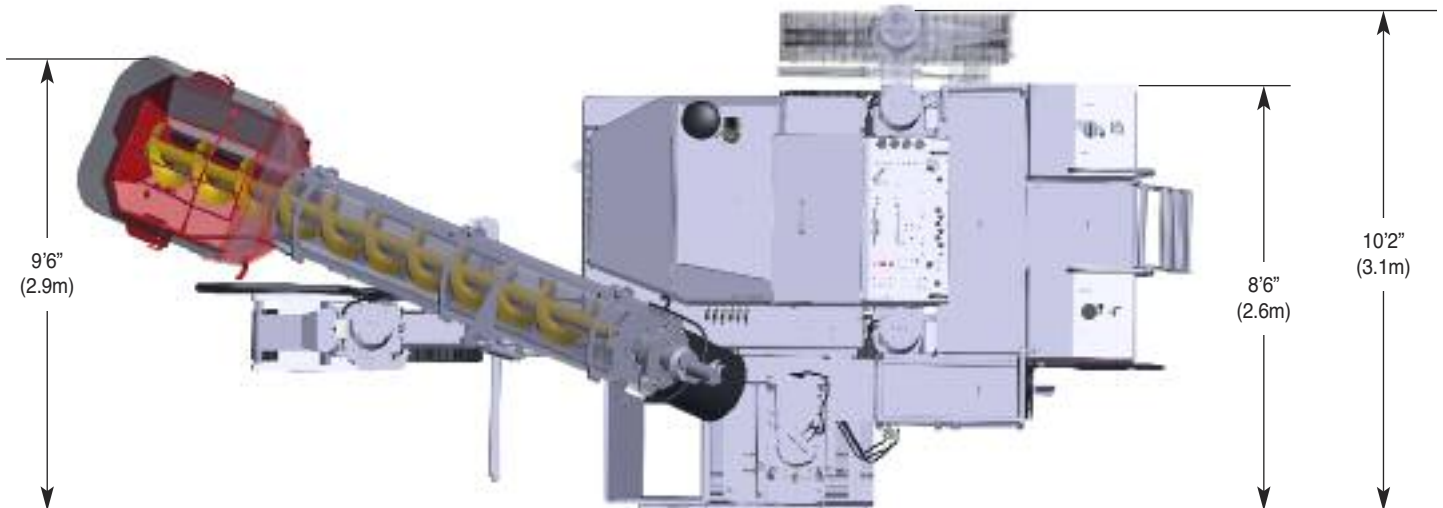

Machine set-up for pouring in a single lane with the ready-mix truck lined up in front.

Power Curbers Family Of Products

Your Single Source for all your Concrete Paving Needs



▲ Power Pavers SF-1700 and SF-2700 Slipform Pavers



▲ Power Pavers Full-Sized, 4-Track SF-2404 Slipform Paver



▲ Power Curbers 7700 Multipurpose Slipform Machine Paving



▲ Power Curbers 7700 Multipurpose Slipform Machine Pouring Variable Barrier



▲ Power Pavers TC-2700 Texture/Curing Machine



▲ Power Curbers 150 Extruded Curb Machine



▲ Anvil American Stringline Accessories

Power & Power Curbers & Pavers

Our Commitment Shows

727 Bendix Drive, Salisbury, NC USA 28146
P.O. Box 1639, Salisbury, NC USA 28145-1639
Tele: (704) 636-5871 Fax: (704) 633-8140
Email: info@powercurbers.com
www.powercurbers.com