

Power Pavers

Our Commitment Shows

SF-1700 Slipform Paver



SF-1700 Slipform Paver

A Low Profile Mid-Sized Concrete Paving Machine

Since 2002, Power Pavers has led the mid-sized slipform pavers market. Designed with a low profile, minimal side clearance requirement, and with simple operation in mind, the SF-1700 offers incredible productivity in a compact package.

Simple controls, excellent operator visibility, and the ability to transport without disassembly make it an operator's dream.

In response to market demand, in the spring of 2011 Power Pavers introduced the SF-1700, a smaller version of the SF-2700. It is specifically designed for half width paving and roads up to 24 feet or 7.5 meters wide.



The minimum paving width for the SF-1700 is 9 feet or 2.75 meters.



Loading and unloading is quick and easy with side ramps.

▲ Visibility

The SF-1700 low profile design gives the operator excellent visibility to both the front and rear of the machine. Unlike frame-over designs, there is no main frame to block the view. The operator can see into the vibration chamber, to the back of the paving pan, and to the finished product. With only 26 inches (66cm) of side clearance required, the machine has the ability to pave close to obstacles.

▲ Simplicity

The machine is equipped with electronic sensors, electronic controls, and an easy to understand control panel. Our easy to operate design contributes towards a quick learning curve.

▲ Transportability

By using side ramps, the machine crawls directly onto a trailer. No expensive disassembly or second truck required, the machine is easily moved from job to job. Because of the low profile design, height clearance requirement is minimal.

▲ Cummins Engine

The 160 HP (119kw) Cummins engine for the SF-1700 provides plenty of power in a quiet package.

▲ Side-Forms Connected to the Tracks

The side-forms automatically adjust with the contour of the grade because they're matched with the tracks. This design also minimizes the distance between the finished concrete and the tracks.

▲ Foldable Containment Noses

Keeping concrete flowing into the paving pan and away from the tracks, the containment noses quickly fold for reduced transport width.

Optional accessories are shown in red.



SF-1700 paving a street with optional integral curb. An optional belt finisher and burlap drag provide the desired finish.



The SF-1700 and SF-2700 frames can be extended to pour over fixed forms.



The side-forms are connected to the tracks.

The Paving System

Machine Features & Functions that make it all come together

▲ Spread Auger and Strike-off Plate

- 16 inch (40.6cm) diameter, split, reversible auger with hard surfaced flighting.
- Each side is individually speed controlled and adjustable in height.
- Evenly spreads concrete across the whole paving width which reduces the volume the machine has to push.
- Strike-Off Plate is hydraulically adjustable so the operator can meter the concrete flow into the enclosed vibration chamber so a constant head pressure is maintained.



The spread auger and strike-off plate.



Vibration chamber.

▲ Vibrators

- Each has individual pressure compensated controls at the operator's fingertips.
- Vertical adjustment is operator controlled with a hydraulic powered lift system.
- Removable baffle plates are between vibrators for use on super-elevated curves.
- **Extra vibrator circuits and vibrators** are available for wider paving widths.
- A **vibrator monitoring system & smart vibrators** are available when monitoring is required.

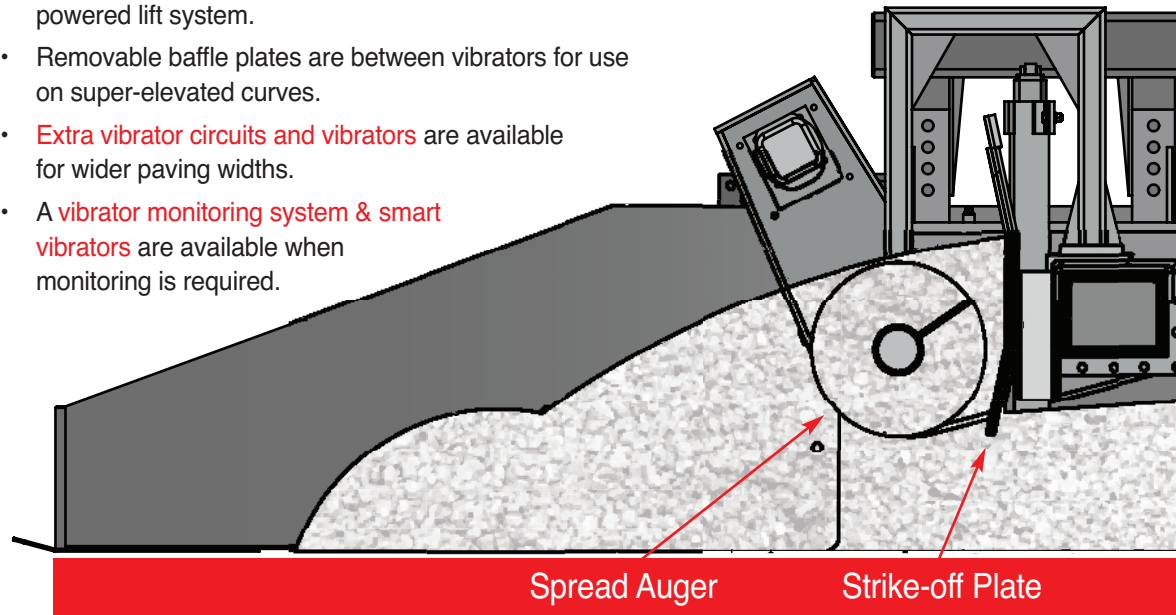

▲ Tamper Bar

- Double tamper bar pushes the larger aggregate down, brings the cream to the top, and minimizes crusting in the vibration chamber.
- Running on an eccentric cam, the two sides are staggered for smoother paving.
- Adjustable in speed of operation, tamper depth, and for crown configurations.



Tamper bar and vibrator mount/lift.

▲ Paving Widths

- The minimum paving width for the SF-1700 is 9 feet or 2.75 meters. Extensions can increase the paving width up to 24 feet, or 7.32 meters. Intermediate widths are achieved by various combinations of extension sections.
- Paving widths are available with either imperial or metric sections.

▲ Profile Pan

- Pan is 46 inches (1.2m) “deep”, is rigidly constructed, and has a sharp square trailing edge which combine to provide a smooth flat finish.
- It features power crowning.
- Pan fits tightly to the side forms to produce a product with a crisp, sharp edge.
- Edge overbuild is standard, allowing each end (at the sides of the paver) to be lifted slightly to compensate for edge slump.
- **Curb mold inserts** can be installed quickly on either or both sides for paving with integral curb(s).



Everything works together to create pavement with a smooth flat finish with a sharp edge (top). Edge overbuild feature compensates for edge slump (bottom).

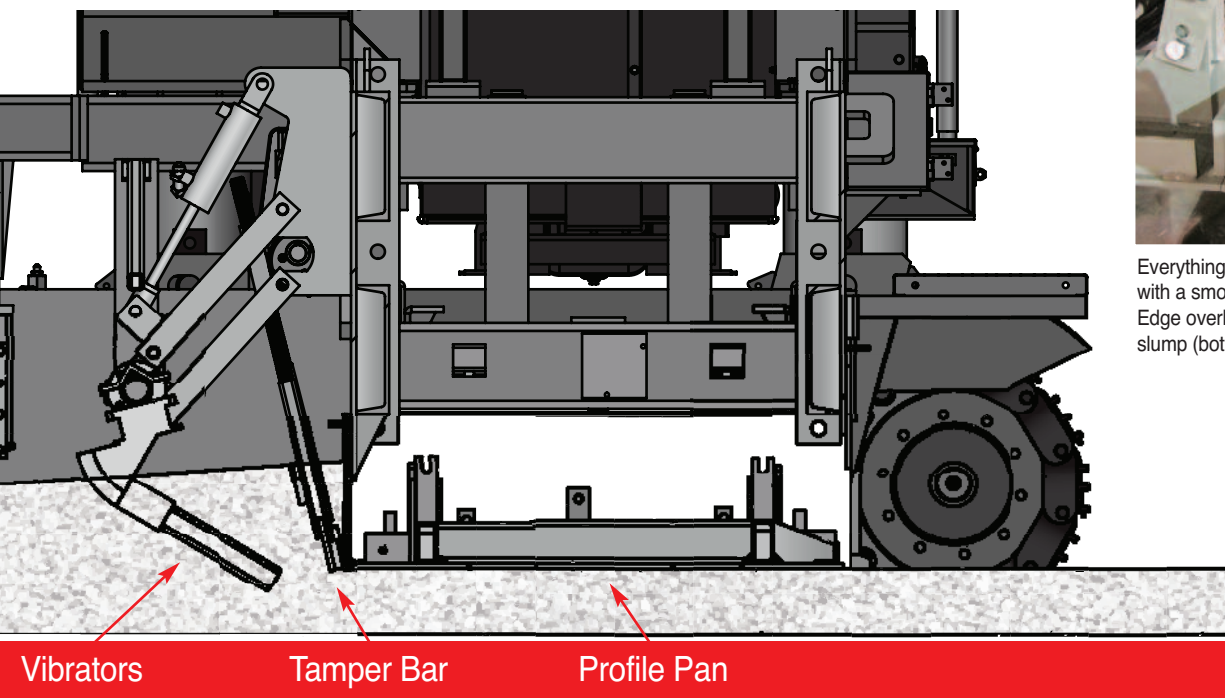

▲ Pressure Washer

- Keeping the paver clean and clear of built-up concrete is imperative for successful paving, so our machines are equipped with a pressure washer with 2,000 psi (138bar).
- Twin tanks provide 220 gallons (833 liters) of on-board water storage.

▲ Control Features and Choices

- Network controller with electronic sensors.
- Electronic Sensors with the Network controller.
- Stringless 3-D “plug-n-pave” ready.
- Synchronized Start/Stop for all Paving Functions by a single switch.
- **Auto Reverse Steering.**
- Pave with dual stringline (four corners) control, single stringline control, or lock-to-grade referencing.
- Connections are provided for either right or left side steering reference.

Optional accessories are shown in red.

SF-1700

Machine Features and Optional Accessories for Enhanced Paving

▲ Hydraulic Sideform Lift

A **hydraulic sideform lift** feature is available to raise the sideforms 4 inches (10.2cm) for clearance while driving around the jobsite.

▲ Moistening the Pavement Surface

A **water misting system** can be added for dampening the surface of the slab or a **burlap drag**.

▲ Integral Curb

A **curb mold** can be added to one or both sides where integral curb is required. They must fit into a 12 inch (30cm) wide by 8 inch (20cm) high area. **Consult the factory for other required curb profiles.**

▲ Steel Reinforcement & Load Transfer

- **Center and Quarter-Point Bar Inserters:** Hydraulically depresses 30 to 36 inch (75 to 90 cm) long bars into the slab at the center and/or quarter-points of the pavement width.
- **Side Bar Inserters:** Available for either or both sides and with manual or hydraulic operation. Includes side trail form(s).
- **Key-Way Inserter:** Installs continuous key-way, on one or both sides, with key-way holder, ribbon type with pre-punched holes. Key-way material not included.
- **Male Key-Way:** Sideform block-out (factory installed) on one or both sides.

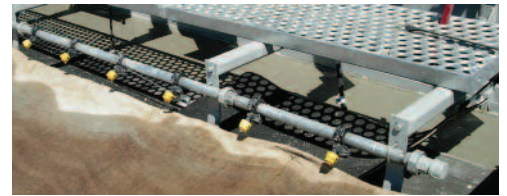

Optional water misting system.



An optional curb mold, even for specialized profiles, can add integral curb to one or both sides of the pavement.

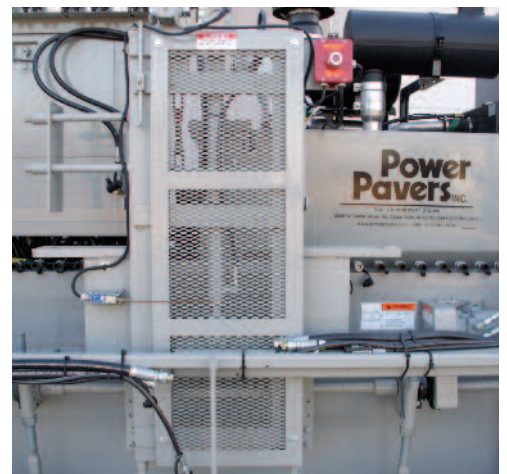

Optional center and quarter-point tie bar inserters.



Edge of pavement with optional key-way inserter (top), and optional male key-way block-out (bottom).



Optional hydraulic side bar inserter.
A manual version is available too.

▲ Polyurethane Track Pads

In lieu of our standard steel pads, **polyurethane track pads** are available for applications where the paver is crawling on existing pavement.

▲ Finishing

- **Belt Finisher:** Hydraulically driven belt finisher with 20 inch (50.8cm) wide belt.
- **Trailing Float Pan:** Adjustable in width to match the paver. Requires side trail forms.
- **Final Finisher:** Oscillating mechanical float, adjustable to match the paving width.
- **Side Trail Forms:** Available for one or both sides. They're required to be used along with side bar inserters and a trailing float pan.

▲ Stringline or Stringless

- **Stringline Accessories:** Stakes, rods, clamps, string, winches, radius materials, etc. are available separately or in kits.
- **Stringless 3-D Kit:** Masts for two prisms and a power conditioner are required for use with 3-D control systems.

▲ Work Bridge

The **WB-2700** is our economical yet durable work bridge for use when manually applying curing compound and texture. It is available in widths up to 40 feet (12m) allowing the crew access to the full width of the paving.

Optional accessories are shown in red.

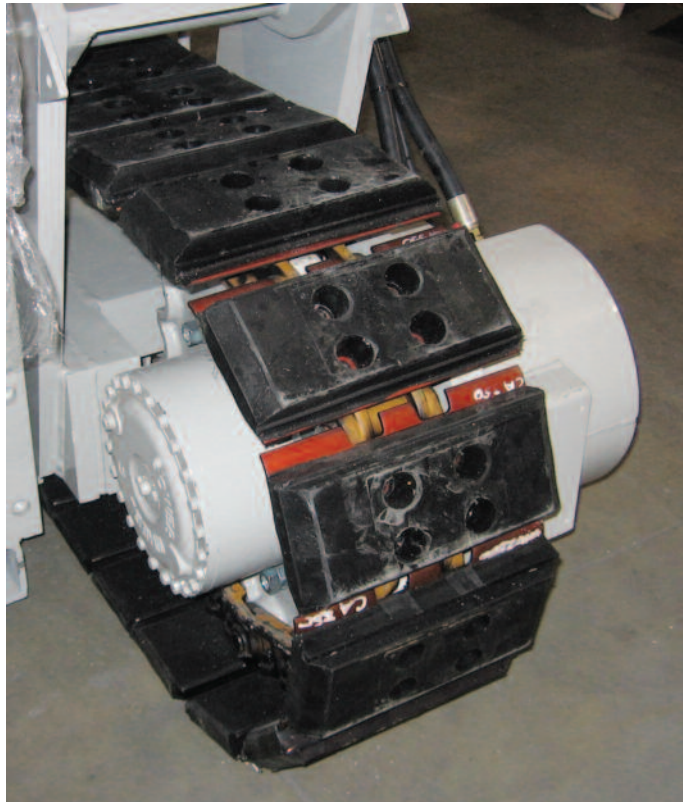

Optional polyurethane track pads.



Optional belt finisher.



Optional final finisher features an oscillation mechanical float.



Optional non-powered WB-2700 Work Bridge gives the crew access to the slab.

Power Pavers & Power Curbers Family Of Products

Your Single Source for all your Concrete Paving Needs



▲ Power Pavers SF-1700, SF-2700 and SF-3000 Slip-Form Pavers



▲ Power Pavers Full-Sized, 4-Track SF-2404 Slip-Form Paver



▲ Power Pavers PS-2700 and PS-3000 Belt Placer/Spreaders



▲ Power Pavers TC-2700 Texture/Curing Machine



▲ Power Curbers 7700 Multipurpose Slip-Form Machine Pouring Barrier



▲ Power Curbers 5700-C Slip-Form Curb Machine



▲ Power Curbers 7700 Multipurpose Slip-Form Machine Paving

Power Pavers

Our Commitment Shows

5838 West Cedar Wapsi Road
Cedar Falls, IA 50613 USA

Tele: (319) 987-3070 Fax: (319) 987-3074

Email: info@powerpavers.com
www.powerpavers.com